

TV TRANSMITTER TECHNOLOGY: PAST, PRESENT & FUTURE



Martyn Horspool
TV Product Manager
GatesAir



2019 WBA
Broadcasters
Clinic



Connecting for the Future





1. THE PAST

WHO INVENTED TELEVISION?

- Early mechanical systems involved rotating wheels with holes and lights
- Poor picture quality, unreliable, no real future...

John Logie Baird



Scottish inventor, John Logie Baird with his mechanical television – March 1925



1926: Image from Baird's Mechanical Television

1925 – Image from Baird's TV system

WHO INVENTED TELEVISION?

Baird's Mechanical Television System

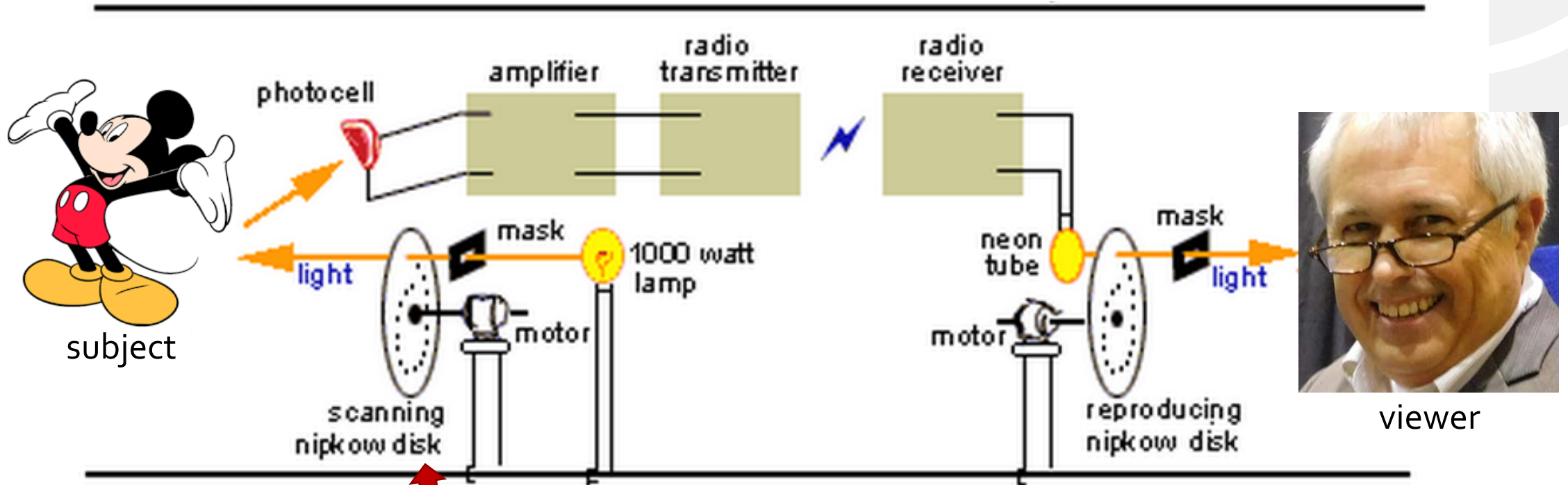

When was the Nipkow disk invented?

Nipkow Disk was patented in 1884!

WHO REALLY INVENTED TELEVISION?

- The “real” inventor of modern television was a Mormon farm boy named Philo Farnsworth:

“As he plowed a potato field in straight, parallel lines, he saw television in the furrows. He envisioned a system that would break an image into horizontal lines and reassemble those lines into a picture at the other end. Only electrons could capture, transmit and reproduce a clear moving figure. This eureka experience happened at the age of 14”

(source: <http://www.technologyreview.com/featuredstory/400802/who-really-invented-television/>)

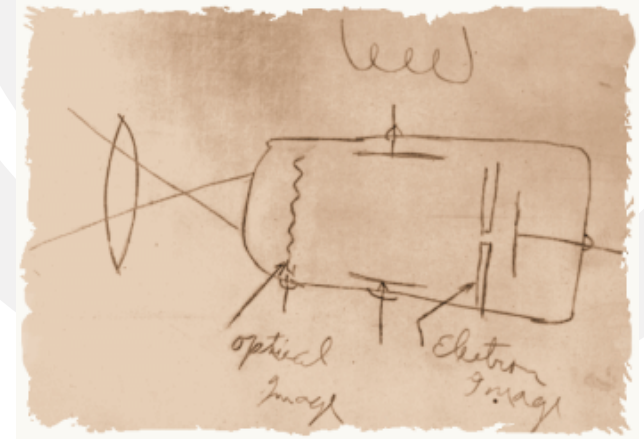
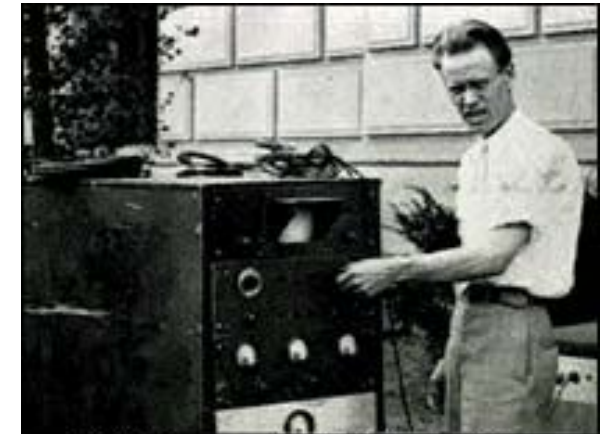

Image sensing device drawn by Farnsworth while at High School (circa 1921)



Philo Farnsworth with his television (1929)

EVOLUTION OF TELEVISION



3" TV, 1928, Resolution 40 lines, 20fps
Cost: **Priceless**

"Retail price comes at around 1.5 Million USD. Orders can be placed now with delivery time mid-2020"



Australian electronics company **C Seed** is releasing the world's largest outdoor TV in 2020
301" Diagonal Screen
Cost: **\$1.5 million**

<https://www.cseed.tv/en/news-detail/14/c-seed-301.html>

OTA TV IS < 100 YEARS OLD

1928 - Philo Farnsworth demonstrates electronic television @ 20fps.

1928 – TV Broadcasting begins from the GE factory in Schenectady, NY, under the call letters W2XB – *48 Lines - was high resolution then!*

1936 - RCA demonstrates 343 interlaced lines at 30fps

1941 - FCC adopted NTSC television std. 525 lines at 30fps. B&W of course!

1953 - First color TV broadcasts in USA

1996 - First ATSC DTV broadcasts in USA – WRAL

2007 - Analog switch-off in USA

2016 – June 29th, WRAL begins Broadcasting ATSC 3.0

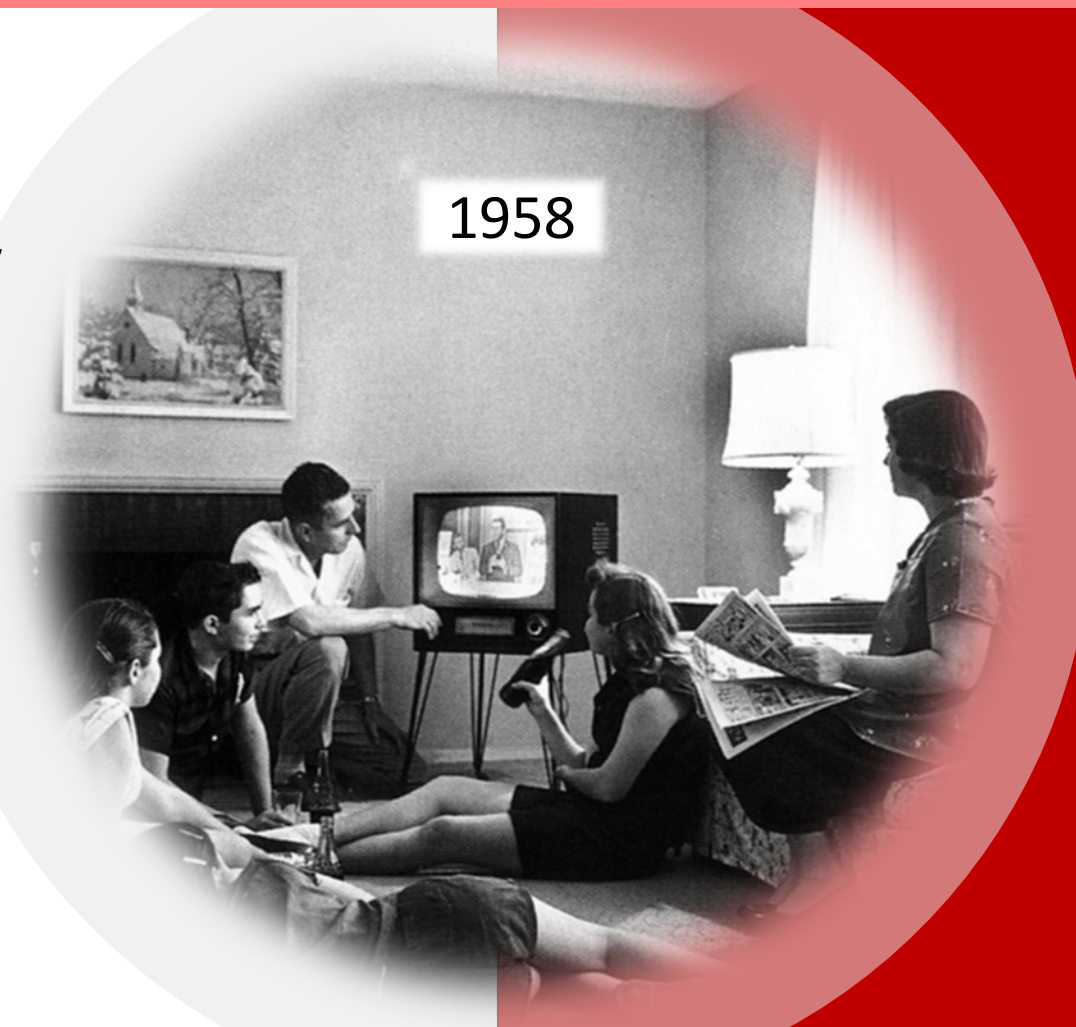

50 YEARS OF UHF-TV TRANSMITTER EVOLUTION



55,000 Watt UHF Color Television Transmitter



MODEL BT-55U

1969 55kW Analog Klystron Tx



1993 30kW IOT Tx



2004 30kW MSDC IOT Tx



2009 12.3kW SS Tx



2019 38kW SS Tx



1980 55kW Analog Klystron Tx

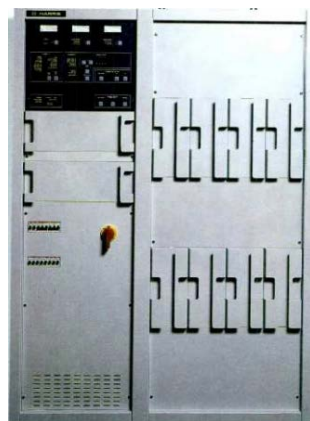

1995 5kW Analog
SS UHF Tx



1998 14kW SS Tx



2004 4.7kW SS Tx



2014 SS Tx



TECHNOLOGY TRENDS

Tx technology - significant trends:

- Vacuum tube to solid-state technology
 - *100% complete all power levels* **Done!**
- Much higher electrical efficiency
 - *Reduced operating costs/TCO* **Ongoing**
- Higher redundancy/reliability **Ongoing**
- Reduced maintenance **Ongoing**
- Higher power density **Ongoing**
- Improved serviceability **Ongoing**



Earl McCune, CPI with an MSDC Klystron
Circa 1996

FROM TUBE TO SOLID STATE

Klystron
(R.I.P.)



varian

IOT &
Klystrode



EEV Power Tubes

~~Diacrode~~

~~TH 680
High-power Diacrode®
60 kW,
common amplification~~



- ~~■ The most powerful~~
- ~~■ The most linear~~
- ~~■ The most compact~~
- ~~■ The most cost effective of all UHF high power components~~

~~**THALES**~~

Bipolar
Transistor



1990 UHF Bipolar
TPV8100B
150W peak 100W CW
8.5dB gain

MOTOROLA

LDMOS
Transistor

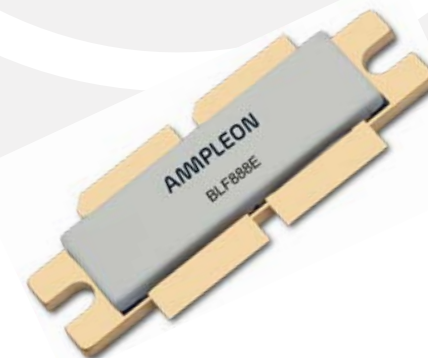

2017 UHF LDMOS
BLF888E
Asymmetrical Doherty
750W (P1dB)
17dB gain

AMPLEON

Q: Which of these Devices was *NEVER* used in a Harris/GatesAir Tx?

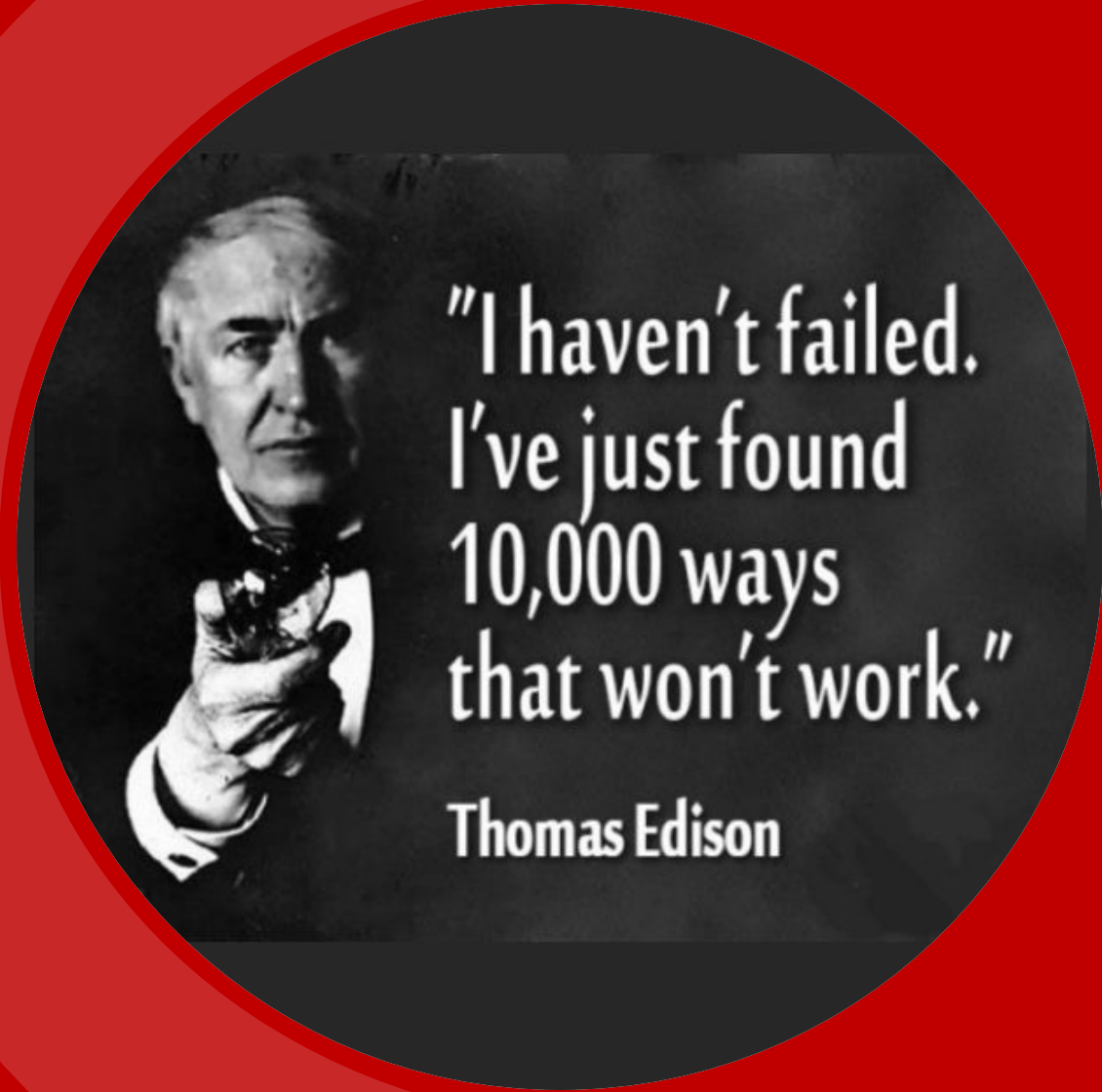

2. WHAT DIDN'T WORK OUT SO WELL?



Success is not final, failure
is not fatal: it is the courage
to continue that counts.

Winston Churchill

IN MEMORIUM... (1)

(PS)²

- A HV Beam Supply with Pulse Step Modulation (using IGBT's)
- 97% efficiency of Power Supply
- Soft start and fast shut off
- Eliminates Crowbar for IOT
- Statement in 1995 NAB Paper:

“Today with (PS)², oil-filled high voltage beam supplies, external voltage regulators, a.c. step-start contactors, and resettable circuit breakers are relics of the past”

- However, It appears no (PS)² systems ever shipped...

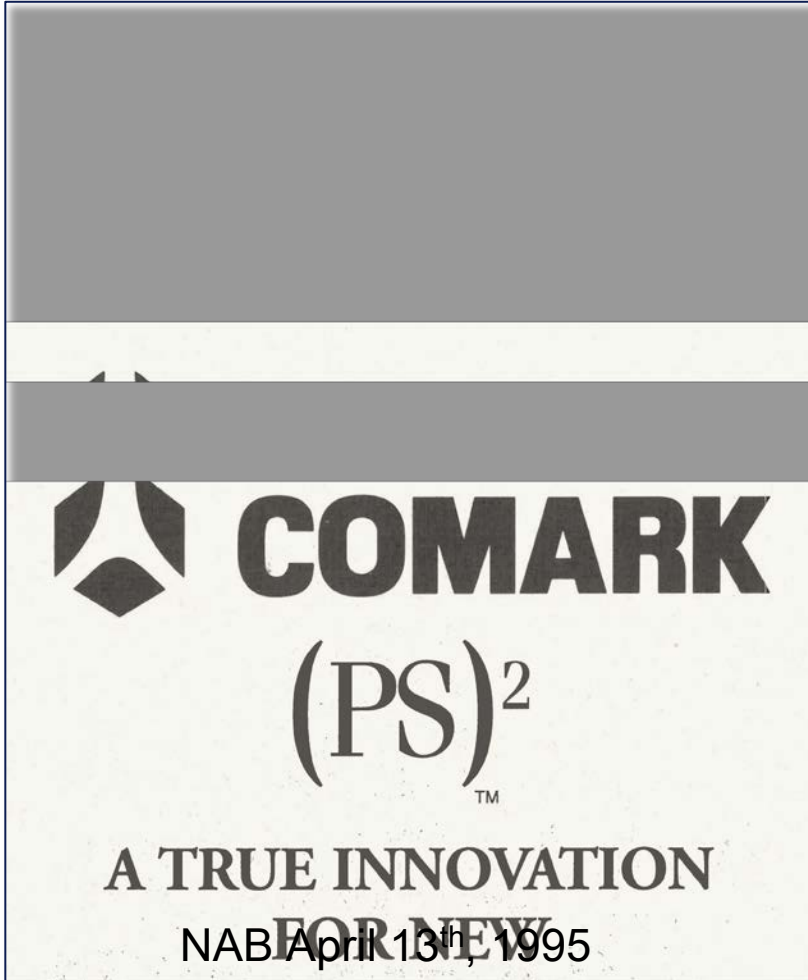

IN MEMORIUM... (2)

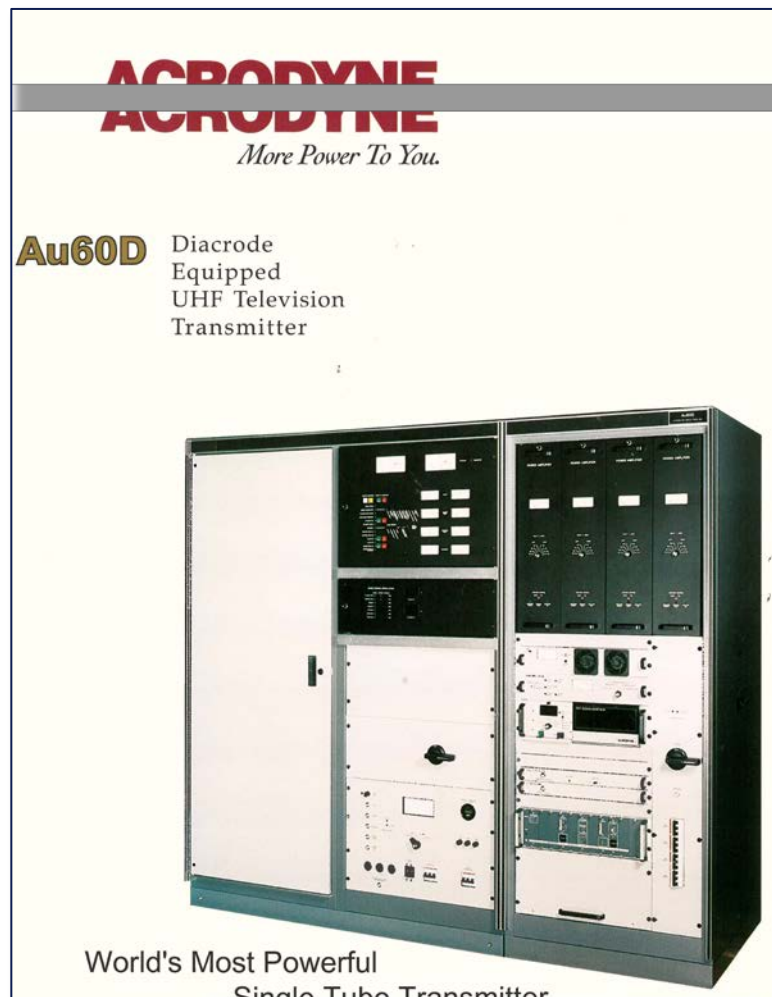

- **The Diacode**



The Diacode®

The TH-680 Diacode is a double-ended tetrode which doubles the tetrode power in a single tube to 80kW visual only or 60kW visual and 6kW aural in combined amplification.

- The Au60D Diacode Transmitter by Acrodyne - 1995
- Acrodyne pioneered Diacode transmitter technology and shipped many
- After a few years however, tube life never lived up to expectations

IN MEMORIUM... (3)

- **Silicon Carbide Transistors**

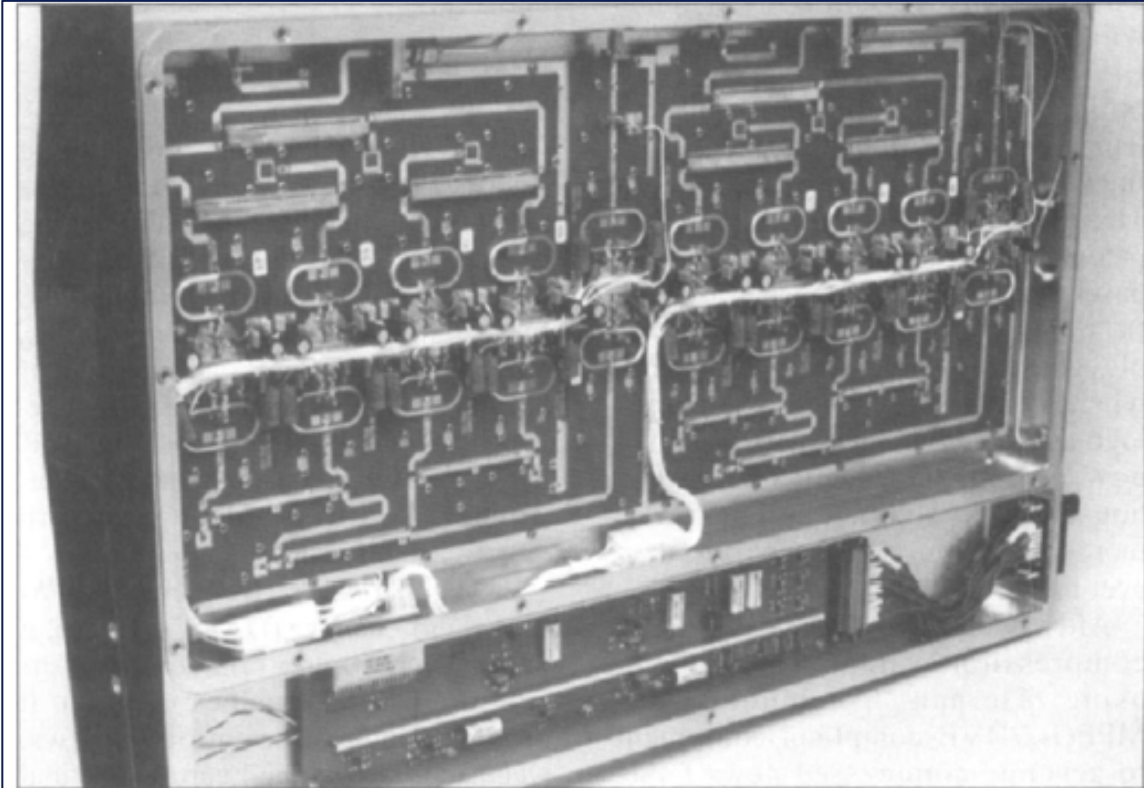

Figure NET-1. The Westinghouse solid-state silicon carbide UHF advanced television transmitter panel assembly.

- Harris Broadcast Division and Westinghouse
- SiC devices promised excellent linearity and efficiency
- Much higher junction temperatures
- 500W transistor, built into 1.5kW power amplifier modules
- A 1.5kW transmitter was deployed at KCTS
- Incorrect turn-on procedure destroyed every transistor!
- Poor device yield and extremely high cost were the final nail in the coffin....

IN MEMORIUM... (4)

Multi-Step Power Amplifier – NEC (late 90's)



(Preliminary)

High Efficiency Digital Multi-Step Amplifier TV Transmitter for DVB

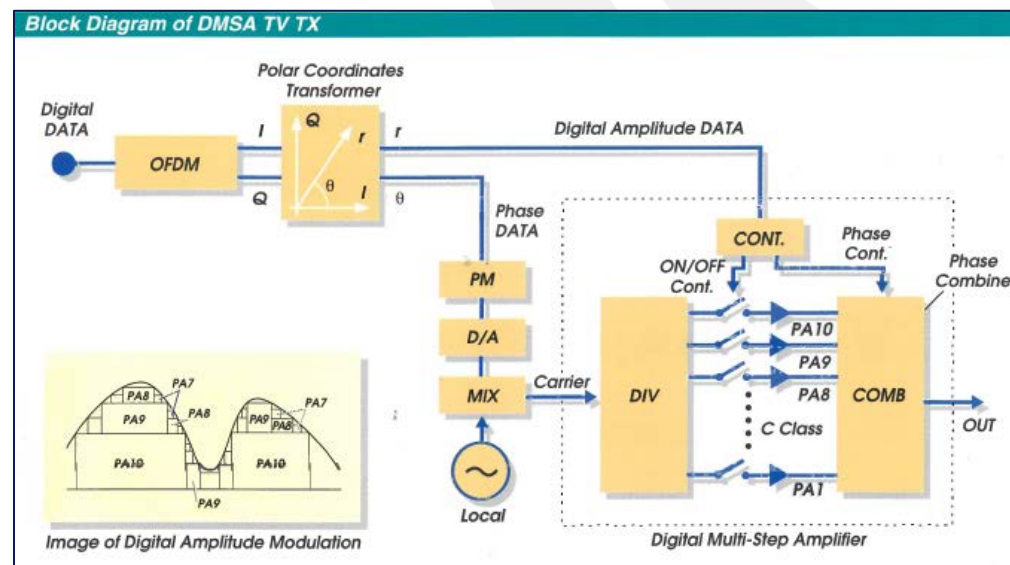



- Class C amplifiers, switched to build the modulation envelope
- Claimed 50% DC to RF efficiency
- None shipped...

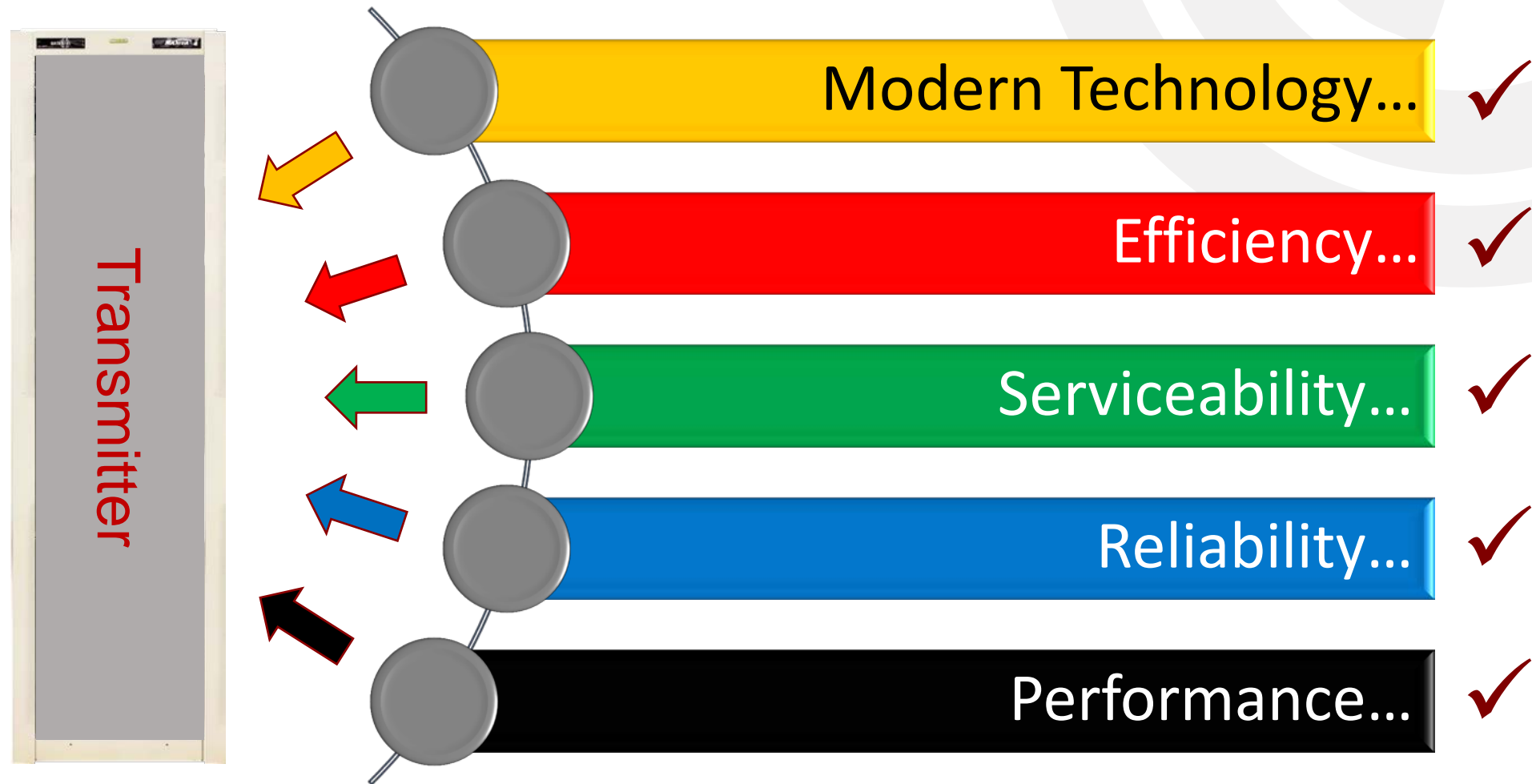

3. THE PRESENT

WHAT DO CUSTOMERS WANT?



MODERN TRANSMITTER TECHNOLOGY

- Modern Technology
 - Microprocessor's, SDRAM, FPGA's, etc.
 - Increased processing speed/power, lower cost than discrete parts, much smaller size
 - Automated pre-correction techniques – far less knobs to adjust
- Surface Mount Technology (SMT)
 - Fast automated PC board production
 - Less cost, higher reliability
- Doherty PA's
 - Higher efficiency, lower energy costs
- Mechanical Design
 - Modern techniques in manufacturing
 - Ease of Assembly & Servicing

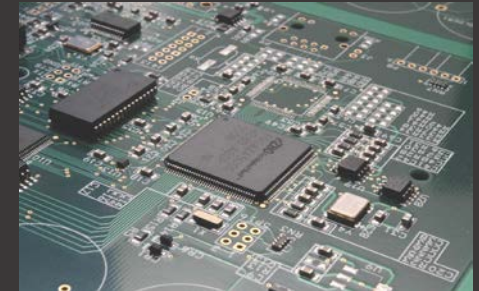
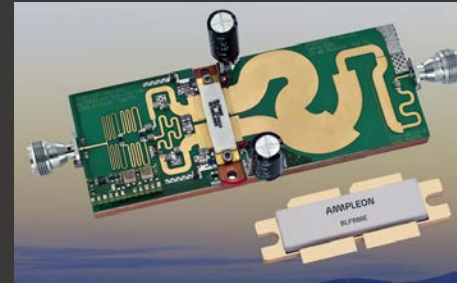
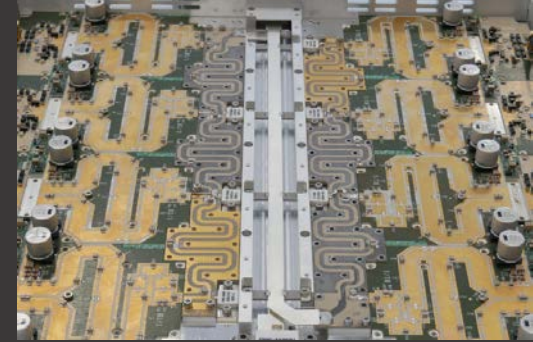

HOW MANY MICRO'S ARE IN THIS TRANSMITTER?

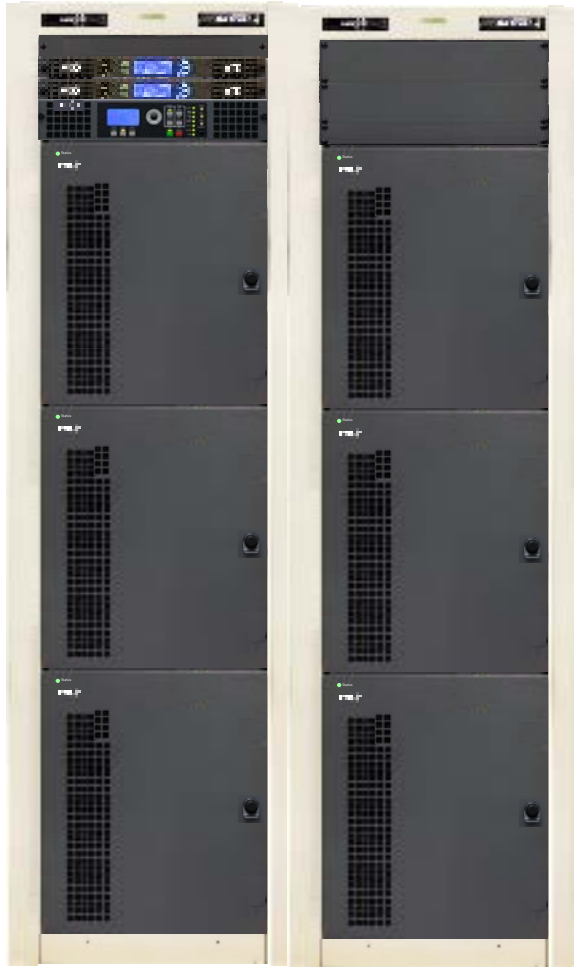

Can anyone guess?

- GatesAir Liquid Cooled UHF – ULXTE-60
- Power Output 38kW Pre-Filter
- Number of PA's = 60
- Number of PA power supplies = 60

And the answer is...

- Number of Micro's = **129**

EXCITER PC BOARD WITH SMT PARTS

XTE Exciter Modulator Board - Modern architecture and devices:

Micro-Processor:

Freescale 1.0 GHz Quad ARM Cortex™ A9 core 2GB DDR3-1066
uSD Card Slot – 32GB

FPGA 1:

Xilinx: 254,200 6-input LUTs,
508,400 Flip flops
28,620Mb Block RAM
1540 DSP Blocks

External Memory

2 – 128Mx16 DDR3L
2 – 1Mx18 SBSRAM

FPGA 2:

Xilinx Kintex7
External Memory
2 – 128Mx16 DDR3L

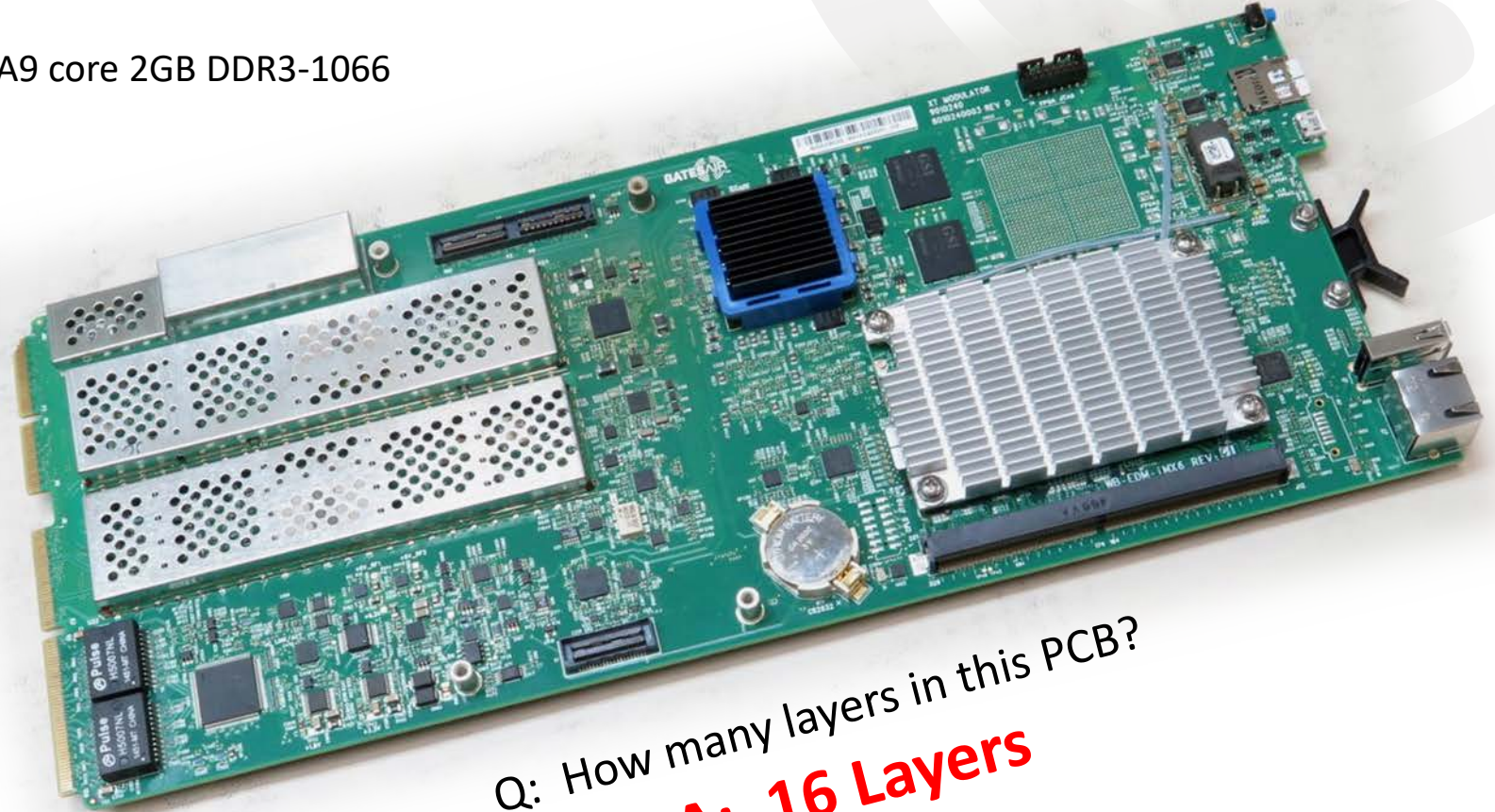

Q: How many layers in this PCB?
A: 16 Layers

DOHERTY AMPLIFIER TECHNOLOGY

- The Doherty Amplifier was invented when exactly?
 - In **1936** by William H. Doherty using tube amplifiers
- Technique involves splitting signal into 2 paths
 - **Carrier amplifier** for the lower power part of the waveform
 - **Peaking amplifier** for the peaks of the waveform
- *Advantage* – Higher efficiency with complex waveforms (>50% at board level)
- *Disadvantage* – Bandwidth limitations due to $\lambda/4$ matching network



William H. Doherty

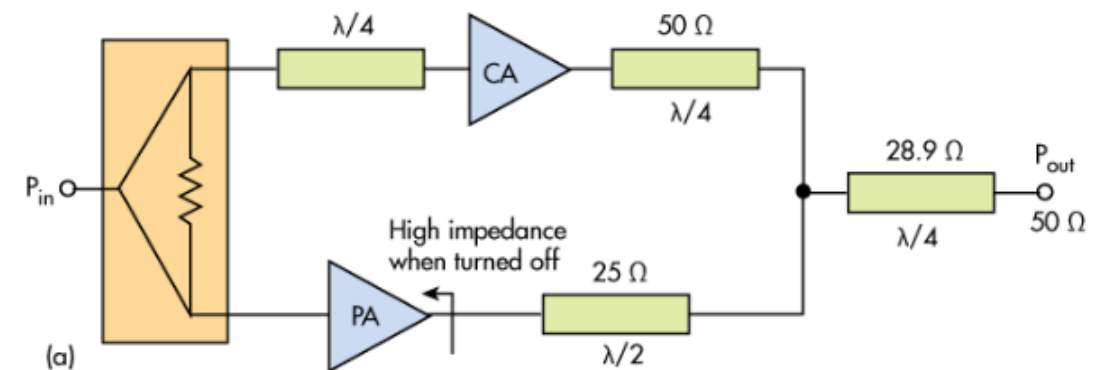
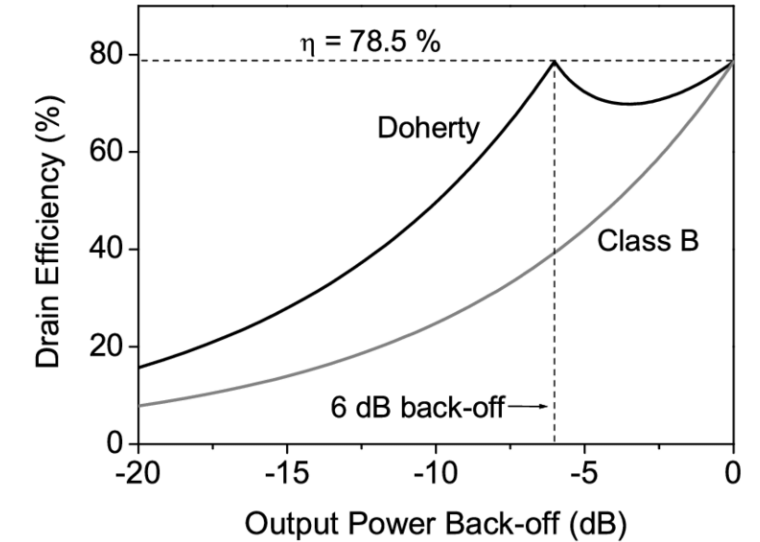

ADVANCES IN UHF RF DEVICE TECHNOLOGY

Ampleon BLF-888E

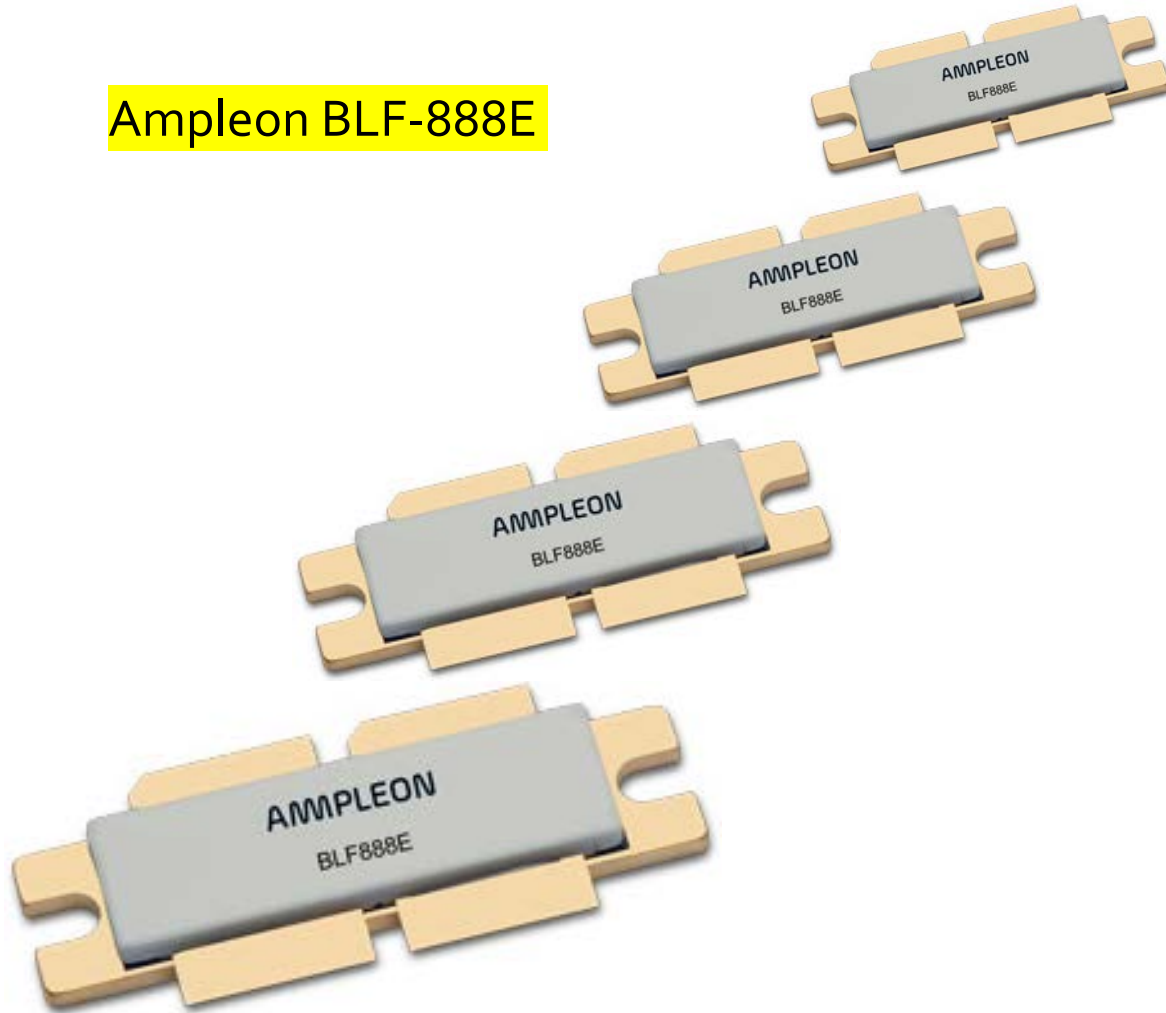

BLF888E Key Features (from data sheet):

- Asymmetrical Doherty
- 50 Volts
- 150W OFDM TV Average Power (25% higher)
- Pallet Efficiency OFDM ~ 52 top 53%
- Gain 17dB
- Doherty back-off (peak/main) 7.96dB
- Excellent ruggedness (VSWR > 40:1)
- Three Doherty designs cover all UHF Band
- One RF PA covers the USA post-repack band

ASYMMETRICAL 2-STAGE DOHERTY

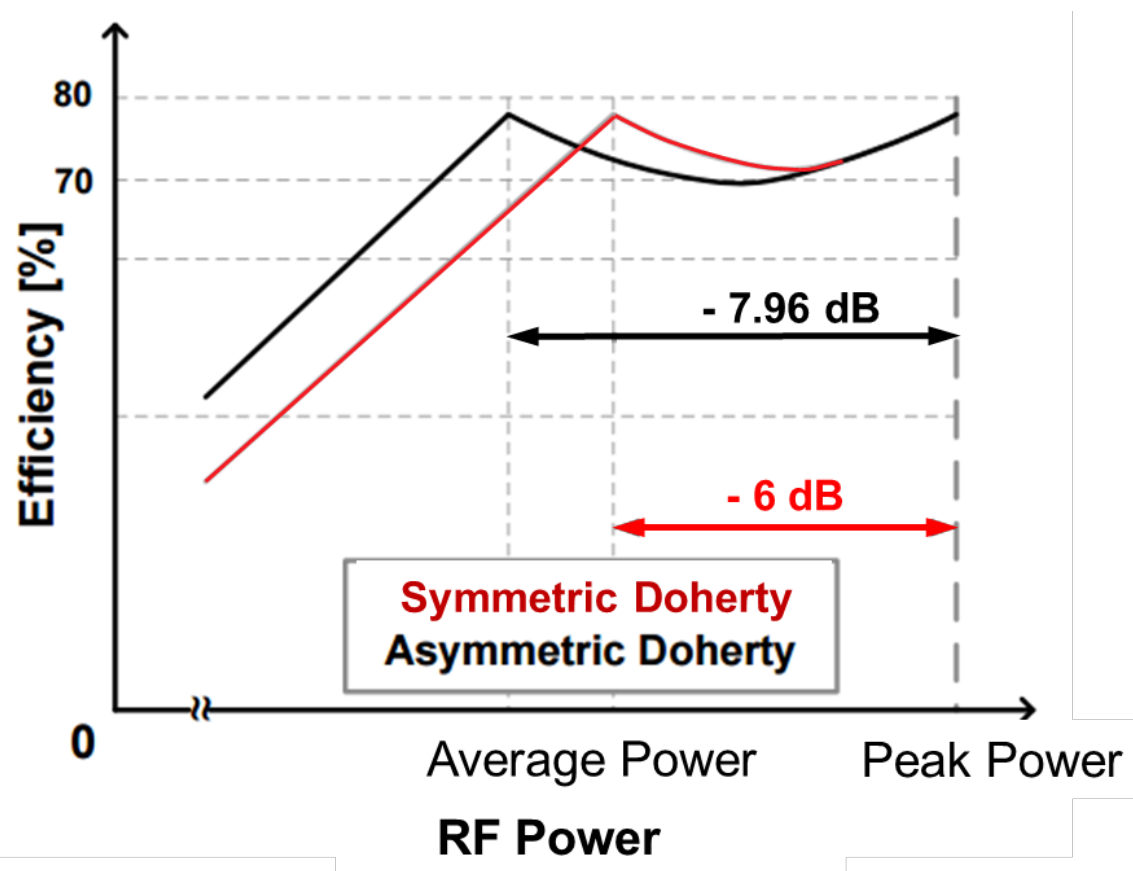

- Asymmetrical Doherty optimizes system efficiency towards higher Peak to Average Power ratio's such as in OFDM modulation (e.g. ATSC 3.0), which is ~ 8dB
- PAR calculation for symmetrical device:
 $= 20 \times \log(1 + \text{peak/main}) = 20 \times \log(1 + (1/1)) = 6.0\text{dB}$
- PAR calculation for asymmetrical device:
 $= 20 \times \log(1 + \text{peak/main}) = 20 \times \log(1 + (1.5/1)) = 7.96\text{dB}$
- Device average power difference (asymmetrical vs. symmetrical):
 $= 10 \times \log(2.5/2) = 10 \times \log(2.5/2) = +0.97\text{dB (+25%)}$

MECHANICAL IMPROVEMENTS – CHILLER PLATE

Early Generation PA Cold Plate (ULX models)

Old Gen

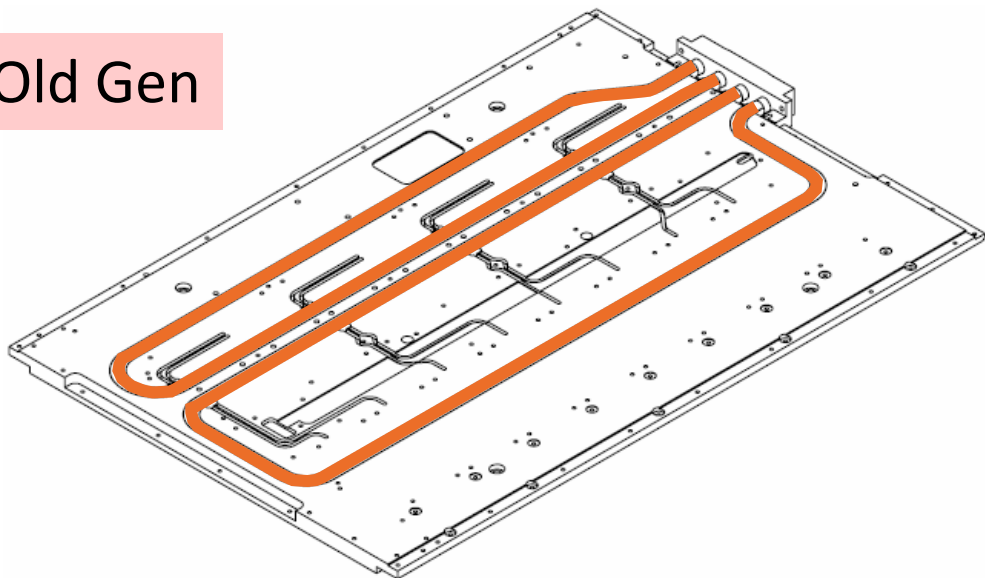

Aluminum plate is milled and a slot machined into it. Copper pipe is press-fit into slot, epoxied and refinished smooth. Costly to make and restrictive flow.

New Generation PA Cold Plate (New GatesAir models)

New Gen

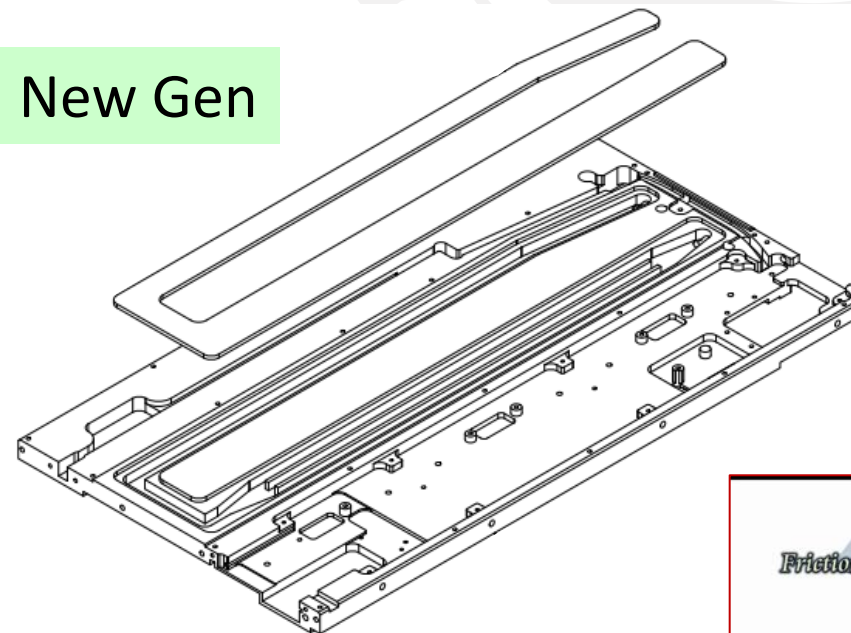

Lower aluminum plate is machined with a wide slot for the coolant. A top plate made of the same material is then "**Friction Stir Welded**" to the main plate. Advantage: same material for weld, strong and reliable.

EFFICIENCY IMPROVEMENTS

- AC to RF efficiency improvements in TV transmitters date back to before 1981 – Example Mod Anode Pulsar in analog klystron transmitters. A 20% reduction in power consumption was achieved.
- Many other advances have been made over the years:
 - **Improved power supplies:** 80% AC to DC efficiency used to be considered excellent but modern switch-mode power supplies reach 96% efficiency.
 - **Improved high-power transistors:** more power and gain per device and more efficient
 - **Improved amplifier techniques:** Doherty, Envelope Tracking
 - **Improved air-cooling systems:** Variable-speed fans
 - **Liquid-cooling** for high power solid state – take the waste heat outside, reduce HVAC costs
 - **Better pre-correction** techniques – allows power amplifiers to be operated closer to saturation



Mod Anode Pulsar
1981

Doherty Amplifier
2016



GATESAIR UHF TX ATSC EFFICIENCY COMPARISON



Includes IOT Systems



From Diamond to ULXTE > 60% AC Power Savings



Connecting for the Future

POWER SUPPLY EFFICIENCY

- Power supplies have improved in efficiency a lot
- Plug-in air-cooled power supplies:
 - Efficiency ~ 96%
 - Power factor > 0.98
 - MTTF 450,000 hrs.
 - Service life > 10 years
 - Efficient enough to justify using in liquid-cooled transmitters
 - Shipped thousands in FM & TV transmitters

CP3000/3500AC54TE Global Platform High Efficiency Rectifier

Input: 100-120/200-277 Vac; Default Output: ± 54 Vdc @ 3000W/3500W; 5 Vdc @ 10W

RoHS Compliant



Features

- Efficiency meets 80plus Titanium requirements
- Compact 1RU form factor with 40 W/in³ density
- Constant power from 52 – 58Vdc
- 3000 or 3500W from nominal 200-277Vac
- 1500W from nominal 100 – 120Vac
- Output voltage programmable from 42V – 58Vdc
- ON/OFF control of the main output
- Comprehensive input, output and overtemp. protection
- PMBus compliant dual I²C serial bus and RS485
- Precision measurement reporting such as input power consumption, input/output voltage & current
- Remote firmware upgrade capable
- Power factor correction (meets EN/IEC 61000-3-2 and EN 60555-2 requirements)
- Redundant, parallel operation with active load sharing
- Redundant +5V @ 2A Aux power
- Internally controlled Variable-speed fan
- Hot insertion/removal (hot plug)
- Four front panel LED indicators
- UL* Recognized, CAN/ CSA† C22.2 to IEC60950-1,
- CE mark meets 2006/95/EC directive[§]
- CB report available

Applications

- 48Vdc distributed power architectures
- Routers/ VoIP/Soft and other Telecom Switches
- LAN/WAN/MAN applications
- File servers, Enterprise Networks, Indoor wireless
- SAN/NAS/iSCSI applications

**3.5kW Power Supply
Weight 4.8lb.**

23 YEARS OF ATSC EXCITERS

- **CD-1**
 - 1996
 - No Adaptive Correction

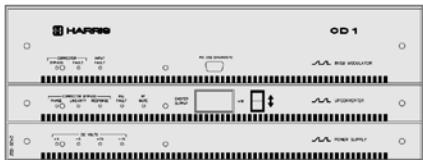

- **CD-1A**
 - 1999
 - Linear Adaptive Correction only



- **Apex (Classic)**
 - 2003
 - Full Adaptive Correction



- **Apex M2X**
 - 2008
 - Full Adaptive Correction
 - S/W Defined Modulation
 - Supports most modulations



V1



V2

- **XTE**
 - 2016
 - Full Adaptive Correction
 - S/W Defined Modulation
 - Smaller
 - Added ATSC 3.0
 - Stores 2 modulations



FLOOR SPACE & VOLUME

Old DTV Tx
12kW

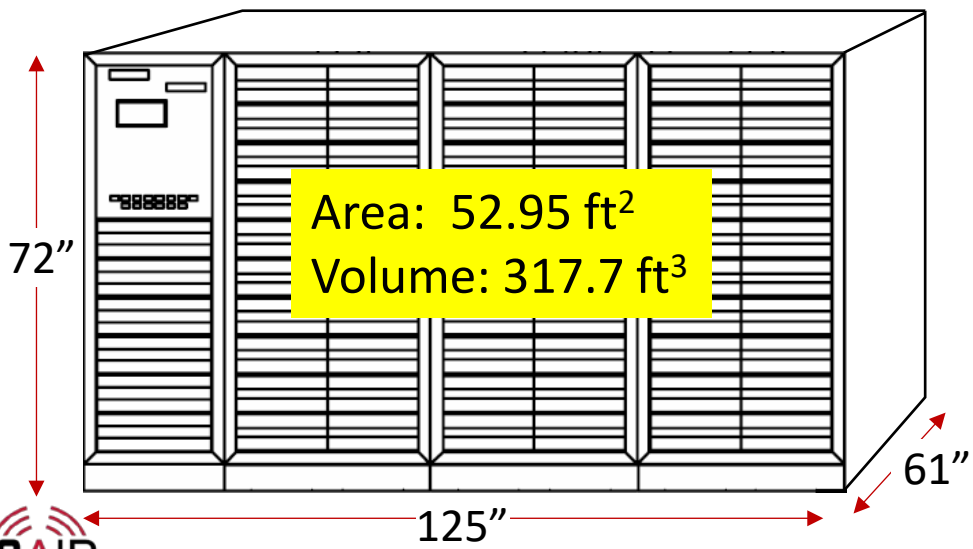

New DTV Tx
12.8kW

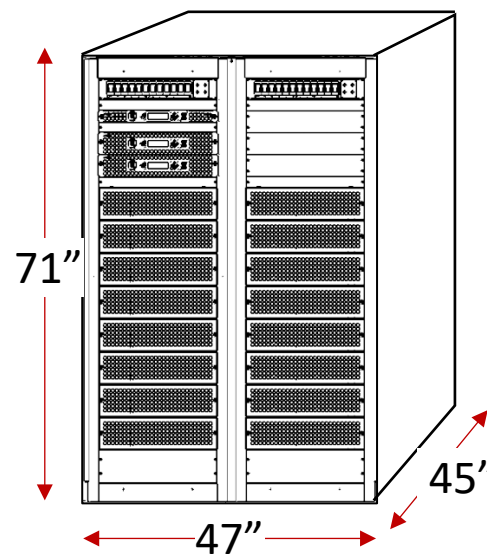
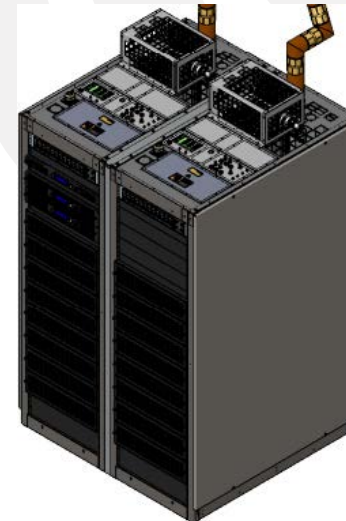



4. THE FUTURE

FUTURE TRENDS (INCLUDES "WISH-LIST" ITEMS...)

Future trends & ideas may include:

- Higher Power RF devices
 - Already in development
- New RF device technologies?
 - What about GaN RF devices?
 - What happened to SiC devices?
- Even higher AC-to-RF efficiency
 - Envelope Tracking / Drain Modulation
 - New techniques being evaluated





A Study and Comparison of Efficiency Enhancement Techniques for RF Power Amplifiers

April 12, 2011
NAB Show 2011

Featuring
GatesAir's



Geoff Mendenhall
Technology Advisor

<https://www.gatesair.com/documents/slides/2011-04-Mendenhall-Study-Comparison-of-Efficiency-Enhancement-for-RF-PAs.pdf>

FUTURE TRENDS (INCLUDES "WISH-LIST" ITEMS...)

Future trends & ideas may include:

- More automated set-up & operation
 - Auto-optimization, Auto power calibration
- Zero maintenance?
 - Well, reduced maintenance...
- Self fault-diagnostics, trend analysis...
 - Transmitter orders parts that are expected to fail...
- Outdoor transmitters (no building required)



HOW LONG WILL OTA TV BROADCAST EXIST?

- 0 - 10 Years – OTA still going strong
 - ATSC-1 to ATSC 3.0 transition, complemented by 5G Broadcast
 - More spectrum juggling? Auctions ☹️
 - OTT (Over-the-top, or delivery of television and film content by internet), will expand given the success of Netflix and others
- 10 - 20 Years – Still around...
 - ATSC 4.0 + 6G, 16K Resolution...
 - Cable disappears...
- 20 - 50+ Years???
 - Mars has its own TV network
 - No need for Broadcast! Implanted brain sensors and ESP take over...
- Question: How long will RF be around?... **Forever!***



(* At least for another $10^{10^{126}}$ Years)

WHAT TO LOOK FOR IN A NEW EXCITER?

- As “future-Proof” as possible
- Software-defined modulation
 - Allows simple and fast updating
- Is it ATSC 3.0 Ready?
 - Store 2 Modulations at same time
 - Redundant IP Transport Inputs
- High-performance using Adaptive Correction
- Internal GPS Receiver vs. External
- Internal UPS or battery back-up
 - Avoids boot-up time after short power outage



Q: Which of these definitely cannot operate with ATSC 3.0?



THANK YOU !

Martyn Horspool
TV Product Manager
GatesAir

2019 WBA
Broadcasters
Clinic



Connecting for the Future